

## 12kV Pole Mounted Outdoor Vacuum Circuit Breaker

**Elektrolites**<sup>®</sup>  
Where Innovation is LIFE

### Summary

This outdoor AC vacuum circuit breaker is used to make and break load current, overload current and short-circuit current in 12kV, 50Hz power system. It is applicable for substations, industry and mining, urban and rural electricity power networks, especially for occasions with frequent operation and automatic power distribution network. It accords with the standard of IEC62271-100 & GB1984: AC high voltage circuit breaker, IEC60694 & GB/T11022: HV General technical requirement of switch and control apparatus.

### Ambient condition

- Altitude: ≤1000mm;
- Ambient temperature: -45°C~+40°C; daily temperature difference: 25°C;
- Wind speed: ≤34m/s;
- Earthquake intensity: 8 degree;
- Relative humidity: monthly average ≤90%, daily average ≤95%;
- Ice thickness: 20mm;
- Applicable occasions should be free from inflammables, explosives, corrosives and severe vibrations.

### Product feature

- Mini vacuum arc extinguish  
High reliability; small volume; long life time; fixed inside the epoxy resin.
- Epoxy resin sealing  
Anti-ozone, anti-ultraviolet; It is firm, light and convenience for transportation.
- Spring mechanism  
Small volume, reliable performance, maintenance free.
- Manual and motor Closing & Opening  
It can be operated by manual and motor, a signal of C/O and storage in outside.
- Switch case  
Aluminium-alloy material, stainless steel and armor plate.

### Technical specification

No.	Item	Unit	Data
1	Rated voltage		12
2	1min. PF withstand voltage(dry/wet)	kV	42(across open contacts:49)/34
3	Lightning impulse withstand voltage(peak)		75(across open contacts:85)
4	Rated current	A	630, 1250
5	Rated short-circuit breaking current		20, 25
6	Rated short-circuit making current (peak)	kA	50, 63
7	3s rated short-time withstand current		20, 25
8	Rated peak withstand current		50, 63
9	Rated operating sequence		O-0.3s-CO-180s-CO
10	Breaking times of rated short-circuit breaking current	Times	30
11	Mechanical duration		10000
12	Rated operation voltage	V	220(DC, AC)
13	Rated voltage of auxiliary loop		220(DC, AC)
14	Rated current of over-current release	A	5
15	Current transformer ratio	A	200/5, 400/5, 600/5 (Protection degree: III class, Class: 0.5)
16	Operating method		Spring operation mechanism (manual /motor)
17	Outline dimension	mm	782 × 222 × 642 (1095 × 225 × 940)
18	Weight	kg	50 (80)

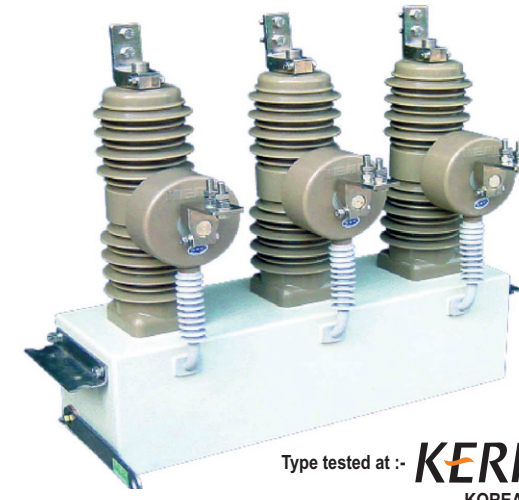

Item	Closing coil	Opening coil	Over-current tripping coil
Rated voltage(kV)	220	220	
Rated working current(A)	AC:<5 DC:<3.2	AC:<1.5 DC:<0.8	5
Voltage and current range under normal working	action on 65%~110% of rated voltage	action on 65%~120% of rated voltage, avoid tripping under less than 30% of rated voltage	action on 100%~110% of rated current, avoid tripping under less than 90% of rated current

### Product structure

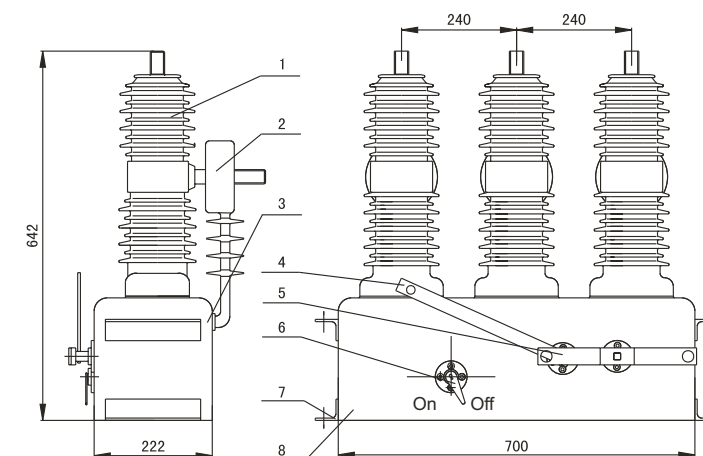

#### Outline diagram

- Solidified sealed pole
- Current transformer
- Aluminium alloy base
- Manual storage handle
- Manual on/off handle
- On/off indicator
- Mounting board
- Spring mechanism(inside)

#### Basic equipments:

- Current transformer protection poles 2 pieces.
- Spring mechanism AC220V.

#### Optional equipments:

- Current transformer, metering and protection poles 2 pieces for each, 75/5 or higher.
- Outside voltage transformer 2pieces (for control power supply and metering).
- Motor spring mechanism AC/DC220/110/48/24V.
- Reclosing controller and series FTU and RTU.
- Disconnect blade.